

SMASH THE STATUES Stage plan

SMASH THE STATUES Technical Rider / PA specifications

The most important thing is that the PA is sufficient for the venue. When we play in a small place we don't expect a full PA.

We try to bring our own FOH engineer: Beau Eckhardt. We will let you know in advance if we will bring him or not.

Smash the Statues travels with their own set of microphones and their own stage rack including mixing desk for our own (wired) in ear mixes and 16 channel passive split. That way we can hear what we want in our own ears and patch to your PA what you feel is necessary for the venue. So we ALWAYS patch the full input list below (we can leave out underheads and snare bottom if necessary).

The stage rack can be on either side of the stage, depending on where your patch is. As long as it is within 3m of the patch (we have a 3m loom from our split).

The minimum channels that need to go to the PA are: kick, sampler and all 3 vocals.

We will always use our own snake (4x stereo jack + 4x XLR) to the front of stage to connect the bass DI and 3 vocals and send back our in ear mixes.

Tom (stage center) doesn't like using in ears so he will always need a wedge (or 2 if available) with lots of his own vocals in it.

If you have more monitors it would be nice to set them up as a back up.

SMASH THE STATUES Channel list

Ch. #	Instrument	Mic	Stand	Insert
1	Kick	99	Short boom	Gate 1
2	Snare top	904	-	Comp 1
3	Snare bottom	904	-	Gate 2
4	Rack tom	904	-	Gate 3
5	Floor tom	904	-	Gate 4
6	Underhead stage R	AE3000	Short boom	
7	Underhead stage L	AE3000	Short boom	
8	Bass DI	Sansamp	-	Comp 2
9	Guitar stage R (Hunk)	906	Short boom	
10	Guitar stage L (Tom)	906	Short boom	
11	Samples	XLR	-	
12	Vox (Hunk)	D5	Long boom	Comp 3
13	Lead vox (Tom)	58	Long boom	Comp 4
14	Vox (Nico)	D5	Long boom	Comp 5

SMASH THE STATUES Stage plan

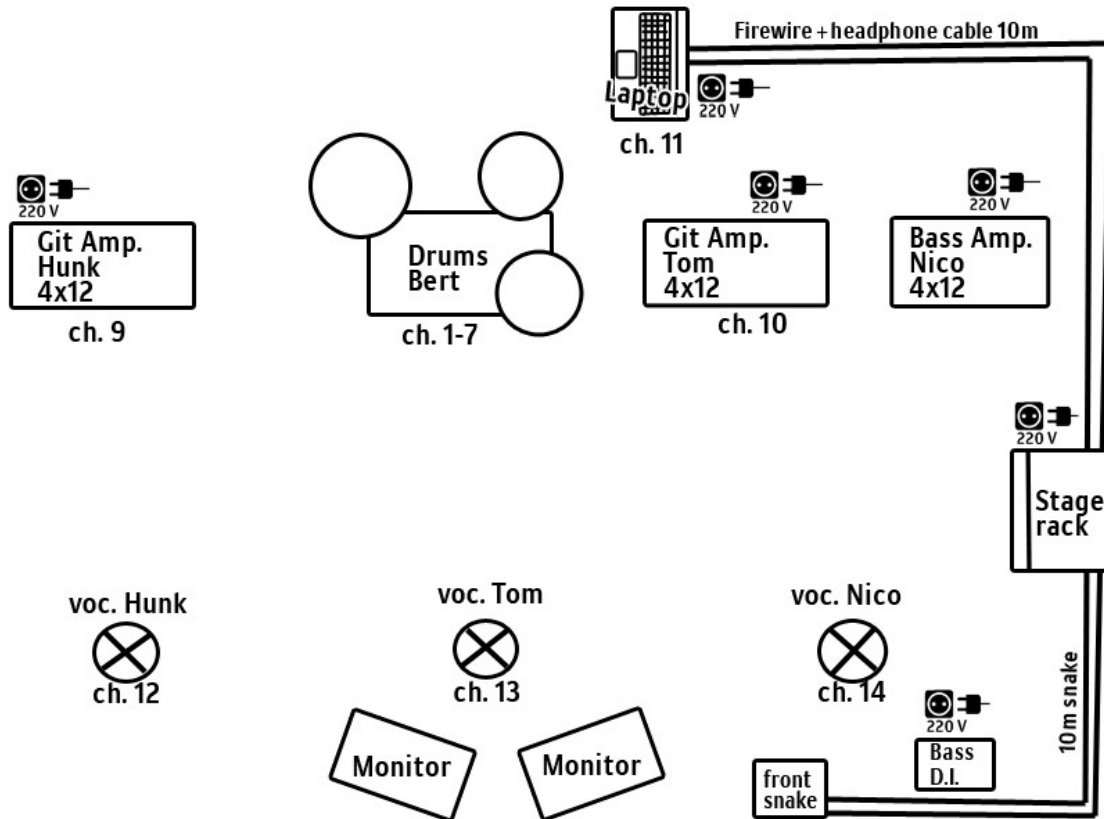

SMASH THE STATUES backline specifications

Drums: 4 piece Premier APX kit consisting of:

- 1 22"x18" kick drum
- 1 14"x5,5" snare drum
- 1 12"x10" rack tom
- 1 14"x14" floor tom

Cymbals: 1 High hat, 2 crashes, 1 ride

Bass: Marquis super bass 100 watt head + Aguilar 8x10 bass cab

Guitar SR (Hunk): Marshall JCM800 2203 single channel 100 watt guitar head + Marshall 4x12 greenback guitar cab

Guitar SL (Tom): Marshall JCM800 2210 split channel 100 watt guitar head + Orange 4x12 vintage 30 guitar cab

These specifications are part of the deal. If these specifications cannot be met, please contact Nico.

Keep in mind that Smash the Statues is a loud band. On small stages the backline alone can easily produce 105 dBA without amplification.

For technical questions contact: Nico van Montfort nvanmontfort@yahoo.com / +31 (0)6 18135980